



www.FGWilson.com

# K7.5-1S



Image for illustration purposes only.

## Output Ratings

Generating Set Model	Prime	Standby
220-240V, 50 Hz	6.5 kVA / 6.5 kW	7.5 kVA / 7.5 kW
240/120V, 60 Hz	8.0 kVA / 8.0 kW	9.0 kVA / 9.0 kW

Ratings at 1.0 power factor.

### Prime Rating

These ratings are applicable for supplying continuous electrical power (at variable load) in lieu of commercially purchased power. There is no limitation to the annual hours of operation and this model can supply 10% overload power for 1 hour in 12 hours.

### Standby Rating

These ratings are applicable for supplying continuous electrical power (at variable load) in the event of a utility power failure. No overload is permitted on these ratings. The alternator on this model is peak continuous rated (as defined in ISO 8528-3).

### Standard Reference Conditions

Note: Standard reference conditions 25°C (77°F) Air Inlet Temp, 100m (328 ft) A.S.L. 30% relative humidity. Fuel consumption data at full load with diesel fuel with specific gravity of 0.85 and conforming to ASTM D975.

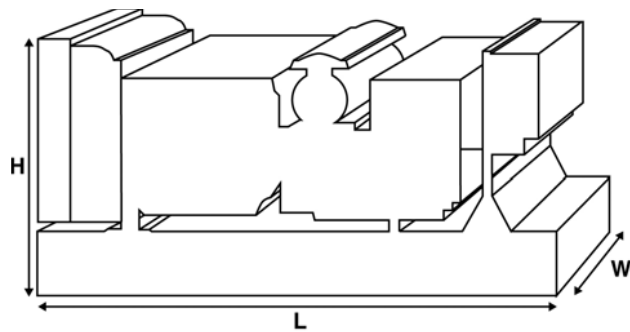

## Ratings and Performance Data

Engine Make & Model:	Kubota D1105-BG2	
Alternator manufactured for FG Wilson by:	Leroy Somer	
Alternator Model:	LLB1114B	
Control Panel:	DCP-10	
Base Frame:	Heavy Duty Fabricated Steel	
Circuit Breaker Type:	3 Pole MCB	
Frequency:	50 Hz	60 Hz
Engine Speed: RPM	1500	1800
Fuel Tank Fillable Capacity: litres (US gal)	62 (16.4)	
Fuel Consumption: l/hr (US gal/hr)		
(100% Load)	- Prime	2.3 (0.6)    2.9 (0.8)
	- Standby	2.7 (0.7)    3.3 (0.9)

## Available Options

FG Wilson offer a range of optional features to tailor our generating sets to meet your power needs. Options include:

- Sound Attenuated Enclosures
- A variety of generating set control panels
- Additional alarms and shutdowns

For further information on all of the standard and optional features accompanying this product please contact your local Dealer or visit: [www.FGWilson.com](http://www.FGWilson.com)

## Dimensions and Weights

Length (L) mm (in)	Width (W) mm (in)	Height (H) mm (in)	Dry kg (lb)	Wet kg (lb)
1400 (55.1)	657 (25.9)	1003 (39.5)	275 (606)	280 (617)

Dry = With Lube Oil

Wet = With Lube Oil and Coolant

Ratings in accordance with ISO 8528, ISO 3046, IEC 60034, BS5000 and NEMA MG-1.22. Generating set pictured may include optional accessories.

Engine Technical Data	
No. of Cylinders / Alignment:	3 / In Line
Cycle:	4 Stroke
Bore / Stroke: mm (in)	78.0 (3.1)/78.4 (3.1)
Induction:	Naturally Aspirated
Cooling Method:	Water
Governing Type:	Mechanical
Governing Class:	ISO 8528
Compression Ratio:	24.0:1
Displacement: l (cu. in)	1.1 (68.5)
Moment of Inertia: kg m <sup>2</sup> (lb/in <sup>2</sup> )	0.76 (2587)
Engine Electrical System:	
- Voltage / Ground	12/Negative
- Battery Charger Amps	30
Weight: kg (lb)	
- Dry	110 (243)
- Wet	115 (253)

Performance	50 Hz	60 Hz
Engine Speed: rpm	1500	1800
Gross Engine Power: kW (hp)		
- Prime	8.4 (11.0)	10.1 (14.0)
- Standby	9.5 (13.0)	11.5 (15.0)
BMEP: kPa (psi)		
- Prime	598.0 (86.7)	599.0 (86.9)
- Standby	676.0 (98.1)	682.0 (98.9)

Fuel System					
Fuel Filter Type:	Full Flow Paper Filter				
Recommended Fuel:	Diesel Fuel No. 2-D				
Fuel Consumption: l/hr (US gal/hr)					
	110%	100%	75%	50%	
Prime	Load	Load	Load	Load	
50 Hz	2.7 (0.7)	2.3 (0.6)	1.7 (0.4)	1.2 (0.3)	
60 Hz	3.3 (0.9)	2.9 (0.8)	2.1 (0.6)	1.4 (0.4)	
	110%	100%	75%	50%	
Standby	Load	Load	Load	Load	
50 Hz		2.7 (0.7)	2.0 (0.5)	1.3 (0.3)	
60 Hz		3.3 (0.9)	2.4 (0.6)	1.6 (0.4)	

(Based on diesel fuel with a specific gravity of 0.85 and conforming to ASTM D975)

Air Systems	50 Hz	60 Hz
Air Filter Type:	Replaceable Element	
Combustion Air Flow: m <sup>3</sup> /min (cfm)		
- Prime	0.7 (26)	0.9 (31)
- Standby	0.7 (26)	0.9 (31)
Max. Combustion Air Intake Restriction: kPa (in H <sub>2</sub> O)	4.9 (19.7)	4.9 (19.7)

Cooling System	50 Hz	60 Hz
Cooling System Capacity: l (US gal)	5.1 (1.3)	5.1 (1.3)
Water Pump Type: Mechanical		
Heat Rejected to Water & Lube Oil:		
kW (Btu/min)	- Prime	-
	- Standby	11.5 (656) 13.6 (773)
Heat Radiation to Room: Heat radiated from engine and alternator		
kW (Btu/min)	- Prime	1.4 (80) 1.8 (102)
	- Standby	1.7 (97) 2.1 (119)
Radiator Fan Load: kW (hp)	-	-
Radiator Cooling Airflow: m <sup>3</sup> /min (cfm)	18.6 (657)	30.0 (1059)
External Restriction to Cooling Airflow: Pa (in H <sub>2</sub> O)	125 (0.5)	125 (0.5)

Designed to operate in ambient conditions up to 50°C (122°F).  
Contact your local FG Wilson Dealer for power ratings at specific site conditions.

Lubrication System	
Oil Filter Type:	Spin-On, Full Flow
Total Oil Capacity: l (US gal)	5.1 (1.3)
Oil Pan: l (US gal)	5.1 (1.3)
Oil Type:	API CH4 15W-40
Oil Cooling Method:	N/A

Exhaust System	50 Hz	60 Hz
Silencer Type:	Industrial	
Silencer Model & Quantity:	IND (1)	
Pressure Drop Across Silencer System: kPa (in Hg)	1.05 (0.310)	1.17 (0.346)
Silencer Noise Reduction Level: dB	9.3	8.6
Maximum Allowable Back Pressure: kPa (in Hg)	7.1 (2.1)	7.1 (2.1)
Exhaust Gas Flow: m <sup>3</sup> /min (cfm)		
- Prime	1.3 (46)	1.6 (57)
- Standby	1.4 (50)	1.8 (63)
Exhaust Gas Temperature: °C (°F)		
- Prime	455 (850)	455 (850)
- Standby	500 (932)	500 (932)

Alternator Physical Data	
Manufactured for FG Wilson by:	Leroy Somer
Model:	LLB1114B
No. of Bearings:	1
Insulation Class:	H
Winding Pitch Code:	2/3 - M
Wires:	4
Ingress Protection Rating:	IP23
Excitation System:	SHUNT
AVR Model:	R220

Alternator Operating Data	
Overspeed: rpm	2250
Voltage Regulation: (Steady state)	+/- 2.0%
Wave Form NEMA = TIF:	100
Wave Form IEC = THF:	3.0%
Total Harmonic content LL/LN:	5.0%
Radio Interference:	Suppression is in line with European Standard EN61000-6
Radiant Heat: kW (Btu/min)	
- 50 Hz	1.7 (97)
- 60 Hz	2.1 (119)

Alternator Performance Data:	50 Hz			60 Hz	
	240V	230V	220V	220V/110V	240V/120V
<b>Data Item</b>					
Motor Starting Capability* kVA	13	12	12	10	12
Short Circuit Capacity %	-	-	-	-	-
Reactances: Per Unit					
Xd	3.130	3.400	3.720	5.490	4.620
X'd	0.670	0.730	0.800	1.180	0.990
X''d	0.336	0.366	0.400	0.591	0.497

Reactances shown are applicable to prime ratings.  
 \*Based on 30% voltage dip at 0.9 power factor.

Voltage Technical Data 50 Hz				
Voltage	Prime:		Standby:	
	kVA	kW	kVA	kW
240V	6.5	6.5	7.5	7.5
230V	6.5	6.5	7.5	7.5
220V	6.5	6.5	7.5	7.5

Voltage Technical Data 60 Hz				
Voltage	Prime:		Standby:	
	kVA	kW	kVA	kW
220V/110V	8.0	8.0	9.0	9.0
240V/120V	8.0	8.0	9.0	9.0

**Documentation**

A full set of operation and maintenance manuals and circuit wiring diagrams.

**Generating Set Standards**

The equipment meets the following standards: BS5000, ISO 8528, ISO 3046, IEC 60034, NEMA MG-1.22.

FG Wilson is a fully accredited ISO 9001 company.

**Warranty**

All prime equipment carries a one year manufacturer's warranty. Standby equipment, limited to 500 running hours per year, has a warranty. For details on warranty cover please contact your local Dealer, or visit our website: [FGWilson.com](http://FGWilson.com).

**Dealer contact details:**



**FG Wilson manufactures product in the following locations:**

Northern Ireland • Brazil • China • India • USA

With headquarters in Northern Ireland, FG Wilson operates through a Global Dealer Network. To contact your local Sales Office please visit the FG Wilson website at [www.FGWilson.com](http://www.FGWilson.com).

FG Wilson is a trading name of Caterpillar (NI) Limited

In line with our policy of continuous product development, we reserve the right to change specification without notice.